

FKID11NSLSLE550  
Iveco Daily 29L to 50C with std fuel tank  
June 2006 onwards  
All Wheelbases  
UK Side Door  
SLE550

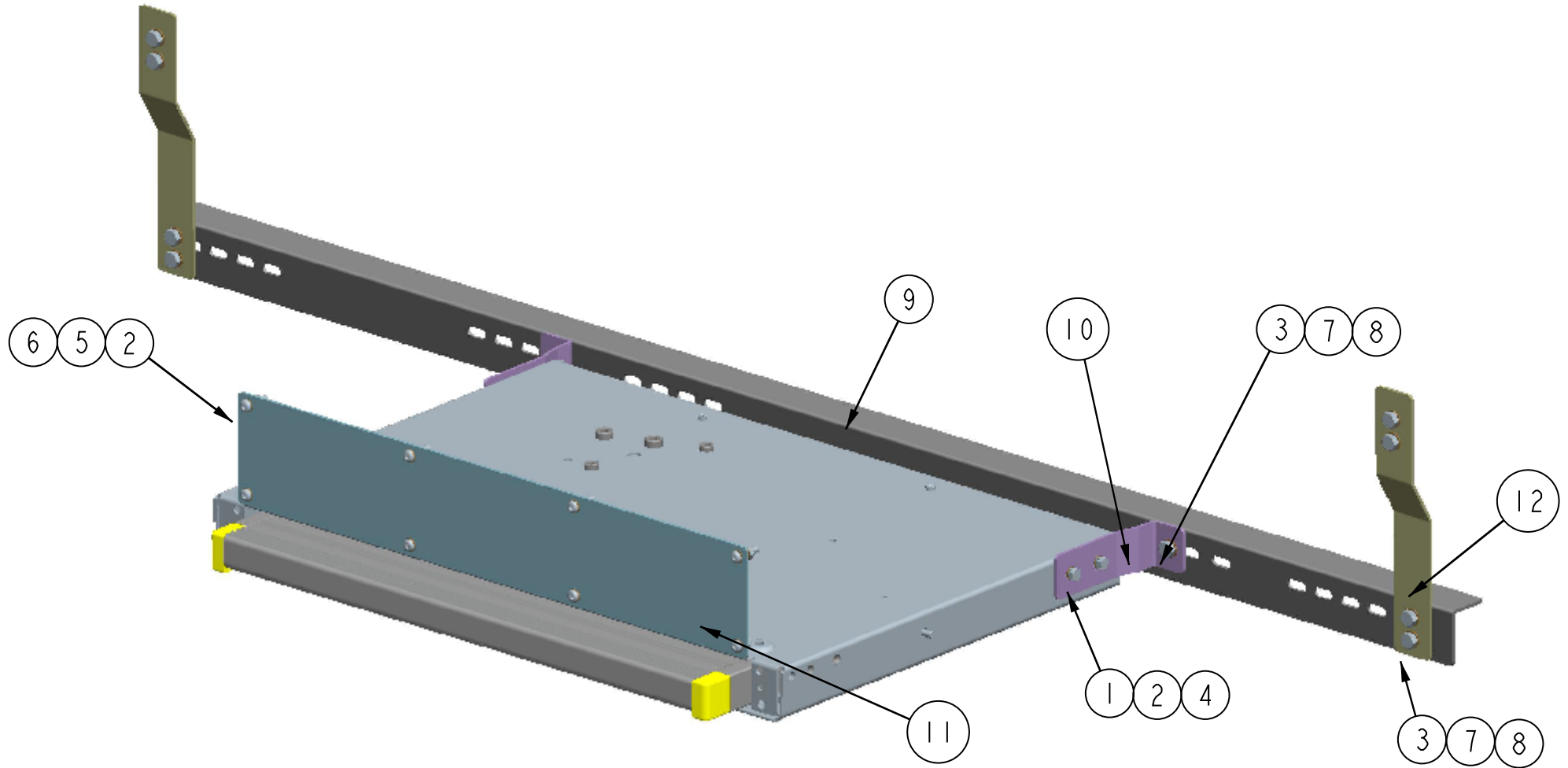

FKID11NSLSLE550

Iveco Daily 29L to 50C with std fuel tank

June 2006 onwards

All Wheelbases

UK Side Door

SLE550

Position rear brackets along cross member  
to avoid fuel tank & drill cross member  
and chassis rail vertical face (to suit  
M8 fasteners)

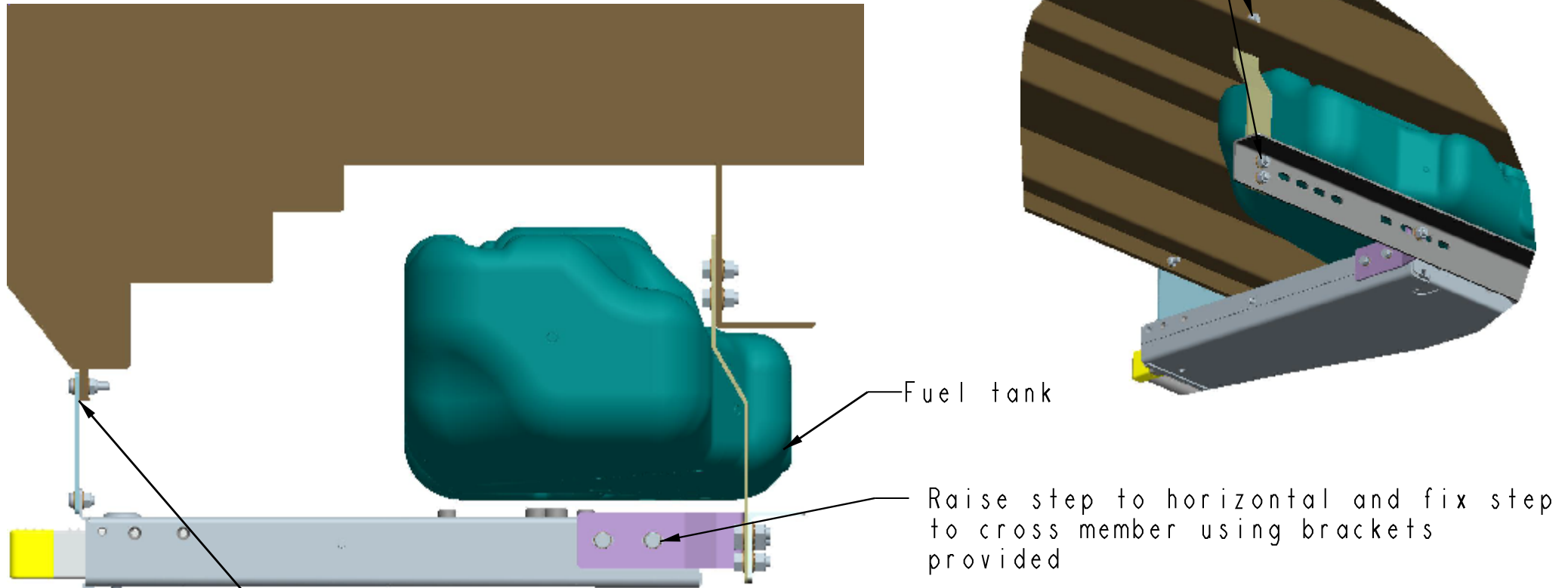

Note:

Space between step & fuel tank approx 15mm

IMPORTANT - The step MUST NOT be fitted touching the tank