

AVS Fitting Kits
Mercedes/VW LT
Side Door
To fit A, K and S 600 C and A/S450C
Side view of installation
Finish in underseal eg Shultz
Underseal to protect on completion.
© Copyright AVS 1999

AVS
COPYRIGHT 1999

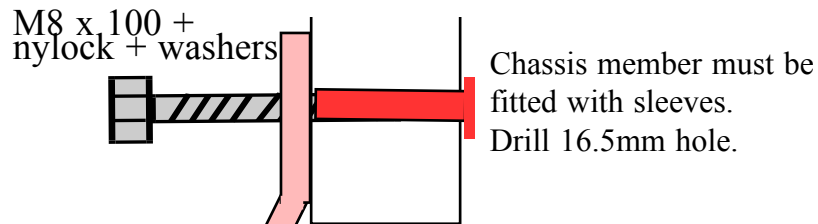

M6 & washers &
nylock

M6, washer
& spring
washer.

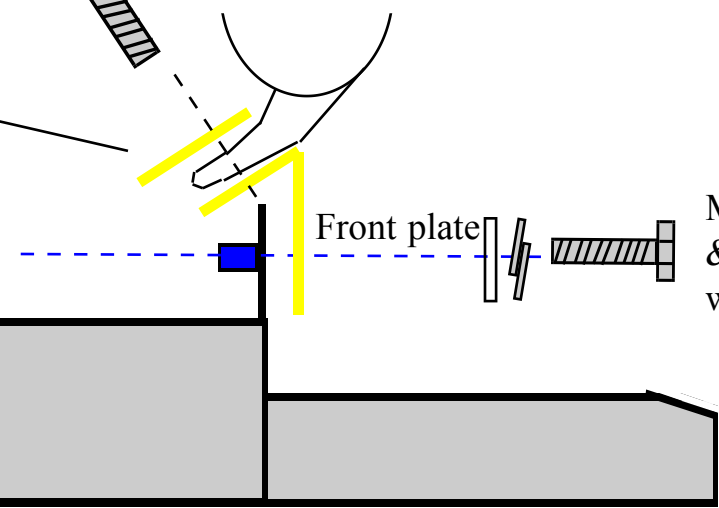
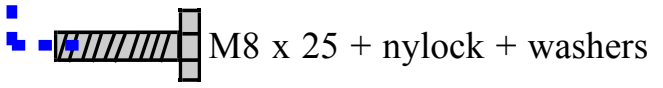
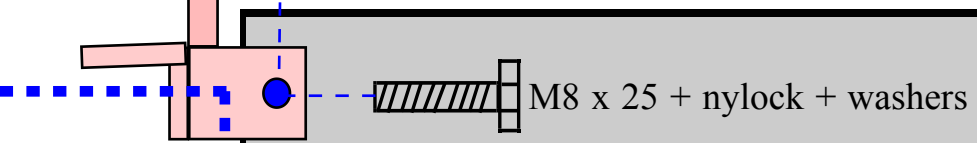

NOTE: Vertical support should be up against van floor to give correct step height.

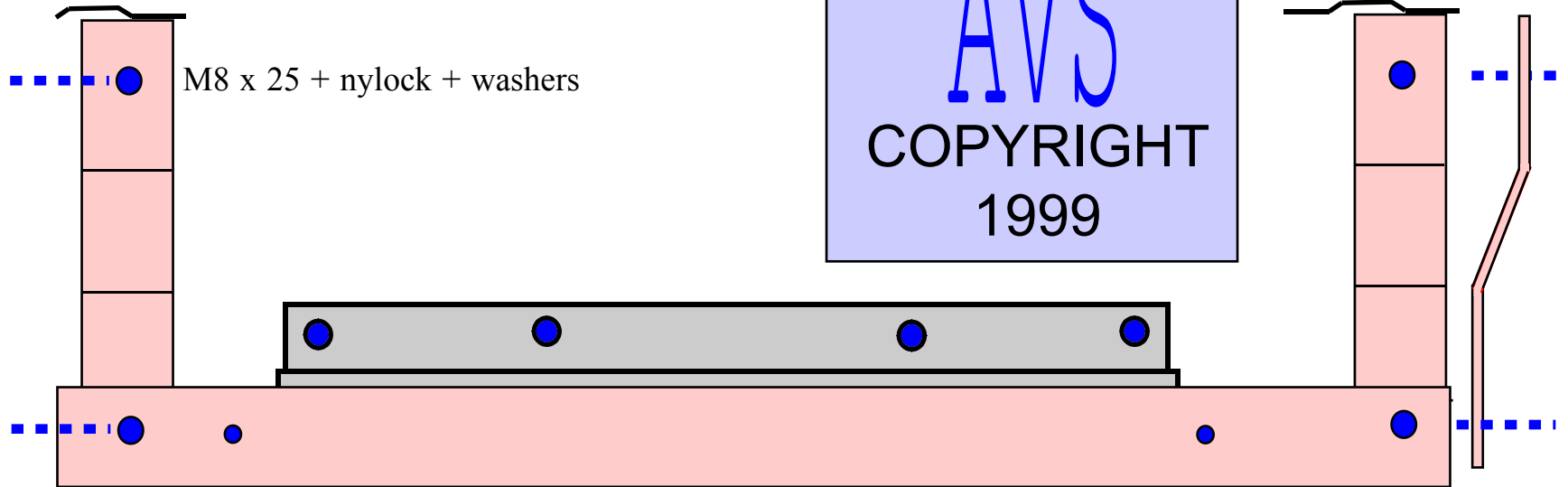

M8 x 25 + nylock + washers

View from above step

M8 x 25 + nylock + washers

M8 x 25 + nylok + washers

AVS Fitting Kits
Mercedes Sprinter
Side Door
To fit A and K 450 and 600 C
General installation plan
Finish in underseal eg Shultz
Underseal to protect on completion.
@ Copyright AVS 1999

AVS

Step Fitting Kit Instructions Mercedes Sprinter / VW LT Side door cassette step

Dec 1999

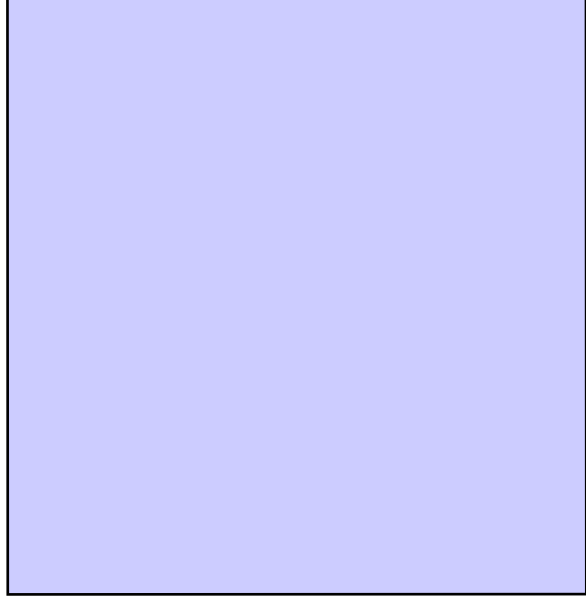

PART REFERENCE:
VEHICLE TYPE

F600CMS
Mercedes Sprinter
VW LT

WHEELBASES
STEP TYPES

LWB,MWB,SWB
A600/450C Electric Cassette Step
S/K600/450C Semi-auto Cassette

Step
ENTRANCE
INSTRUCTION REF

Standard Side Sliding Door
F600CMS

AVS

Alders Farnhouse
Alders Lane
Whixall, Shrops
SY13 2PZ

Tel 01948 880010
Fax 01948 880020
E-mail AVSsales@aol.com

**MERCEDES SPRINTER / VW LT
PARTS LIST:**

PART DESCRIPTION	QTY
Main Cross member (A)	1
LHS (front) "S" 390mm bracket (B)	1
RHS (rear) "S" 360mm bracket (C)	1
Mounting bracket "L"(D)	2
Chassis spacer (E)	2
Spreader plate front	1
Spreader plate backing plate	1
M8 x 100	2
M8 x 25	6
M8 Nyloc	8
M8 flat washer	16
M6 x 25	8
M6 spring washer	4
M6 flat washer	12
M6 Nyloc	4

All AVS fitting kits are double checked before despatch. Please report any shortages within 3 days of delivery and AVS will ensure a prompt response.