

AVS Marketing Ltd
Copyright 2000

AVS Fitting Kits
General
Side Door
To fit A900C or A600C or A450C
© Copyright AVS 2000

In some cases it is easier to mount the universal L brackets to a stringer or chassis member and then pass the uni strut through the bracket.

Extension and joint required on some kits. These items are in your kit if required.

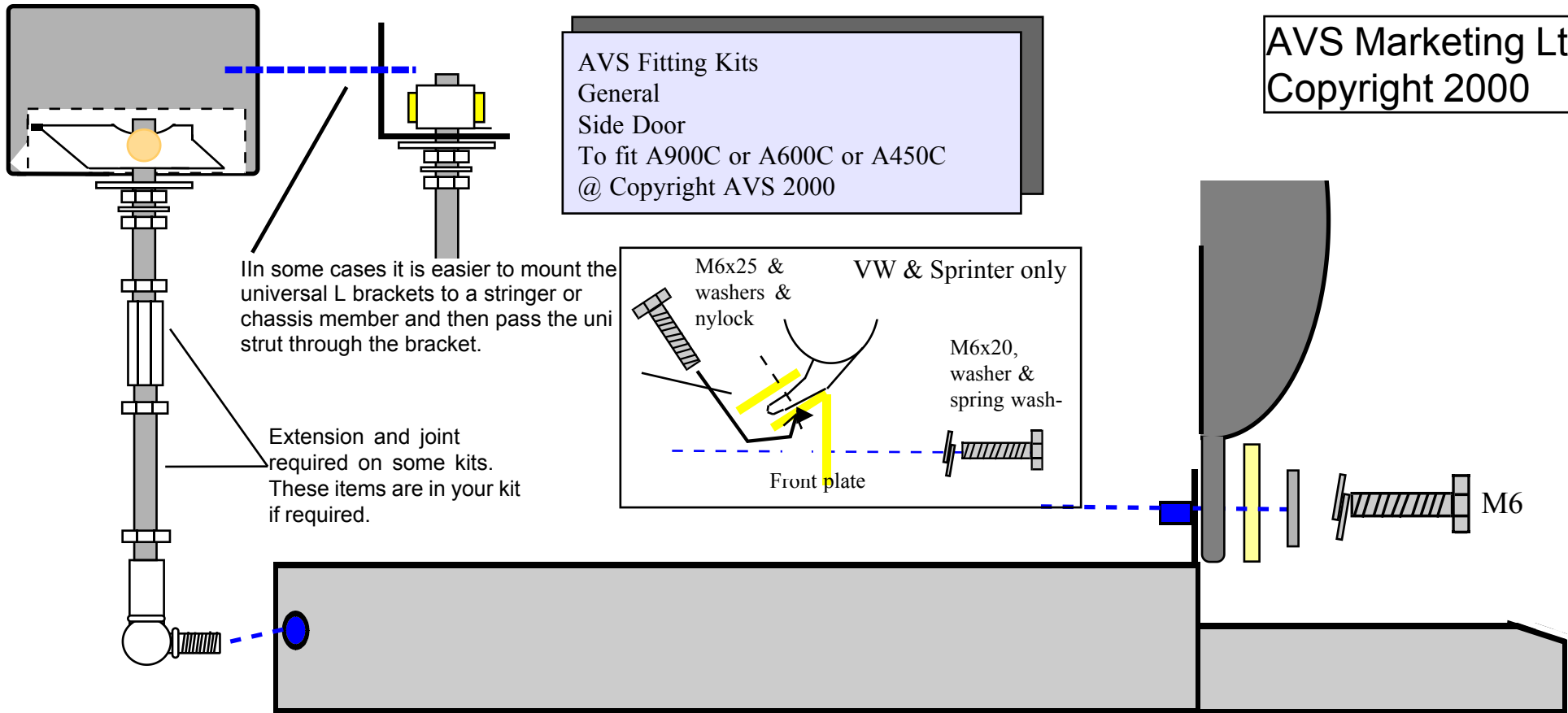
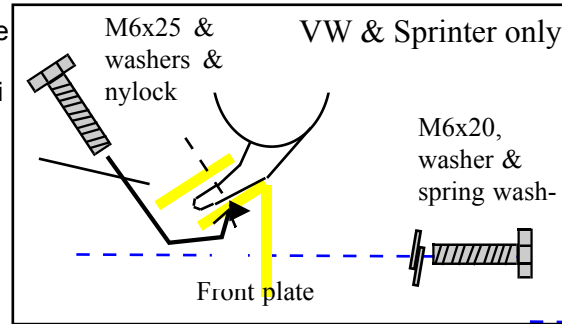

STEP HEIGHTS: In general it is recommended that the step from ground to the new AVS step is 1" (25mm) above the half way point to the next step. For example if the overall step height were 18" The AVS step should be set at 9.5" leaving a 8.5" second step on an unloaded vehicle.

NOTE: Additional parts may be required at extra cost to enable the step to be fitted to some vehicles. The Universal kit is designed to allow AVS steps to fit to as many vehicles as possible. However dropper plates or extended struts or other items may be required in some cases. AVS are unable to ensure that the universal kit alone will fit all vehicles.

AVS Fitting Kits
General
Side or Cab Door
To fit A900C or A600C or A450C
© Copyright AVS 2000

AVS Marketing Ltd
Copyright 2000

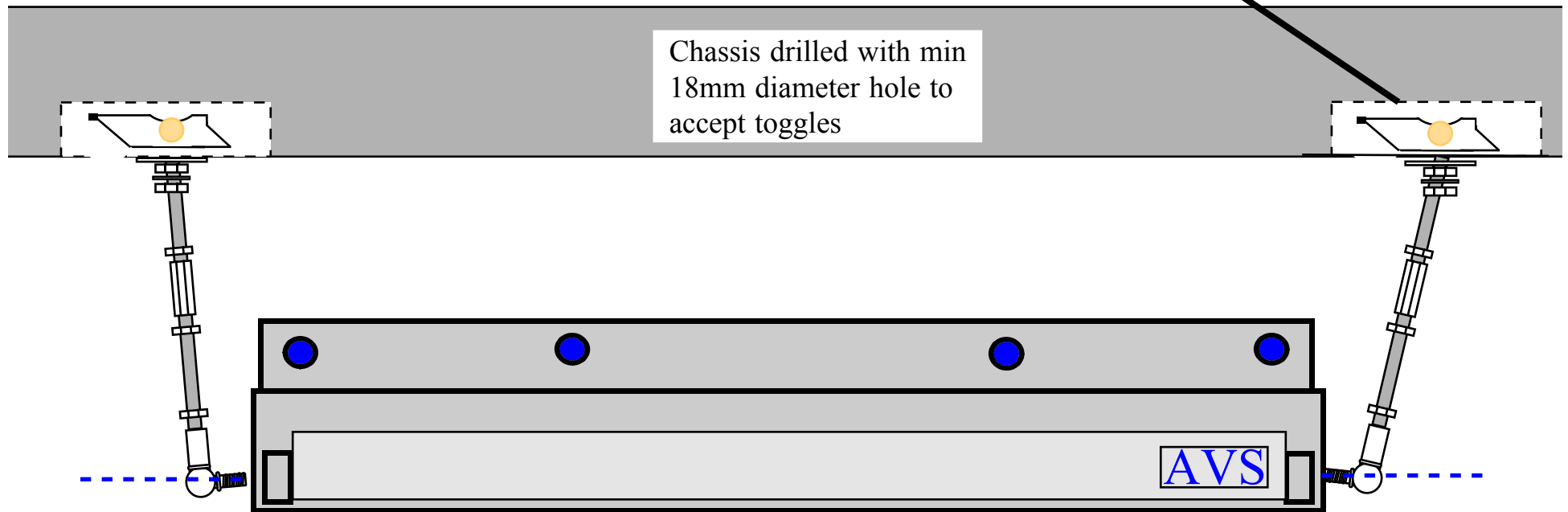
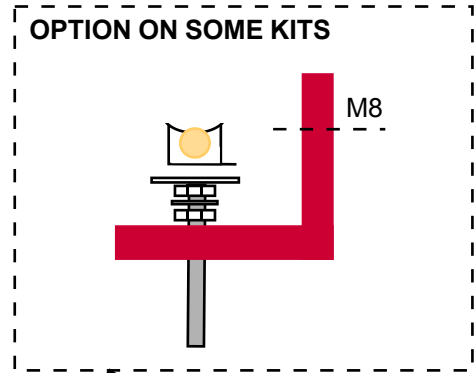

TOGGLE - Toggle is weighted to drop down when passed through the hole drilled in the chassis

1

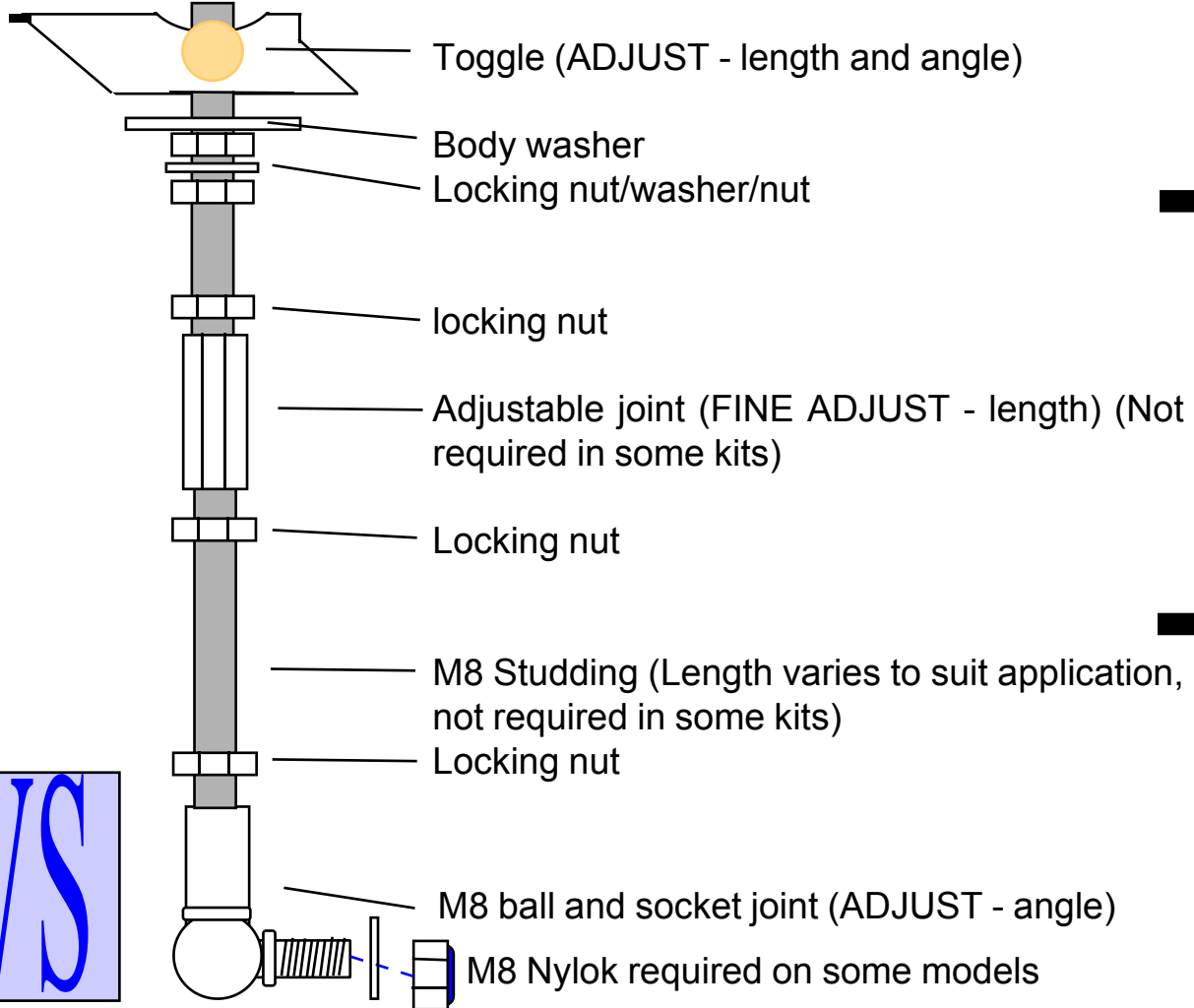
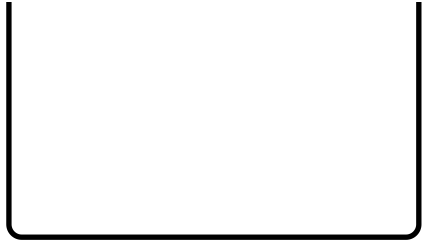

2

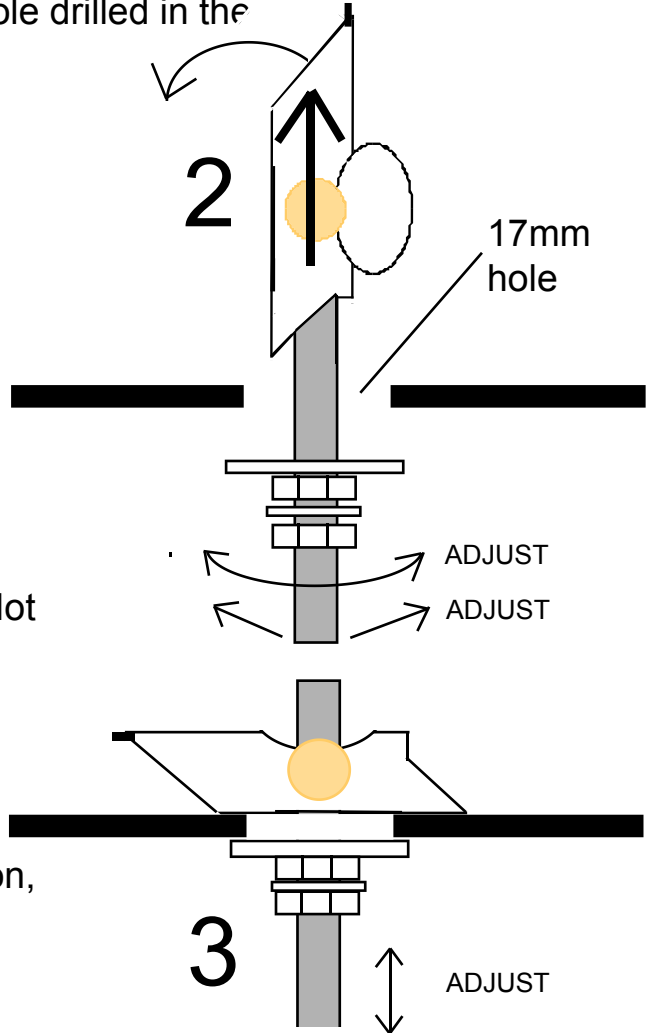

3

ADJUST

